



PRODUCT SPECIFICATION FOR LCD MODULE

MODULE NO. : ET-G240128A
REVERSION : V1
TYPE : COB

Customer Approval:

--	--	--	--

PREPARED BY		DATE	
CHECKED BY		DATE	
APPROVED BY		DATE	



1. General Specifications

Item	Standard Value	Unit
Number of dots	240(W)X128(H)	dots
Display Pattern	<input checked="" type="checkbox"/> Dot-Graphic <input type="checkbox"/> Character <input type="checkbox"/> Digits <input type="checkbox"/> with ICON <input type="checkbox"/> _____	
Module Dimension	144.0(W) X104.0(H) X 14.0(T)	mm
Viewing Area	114.0(W) X 64.0(H)	mm
Active Area	107.95(W) x 57.55(H)	mm
DOT Size	0.40(W) x 0.40(H)	mm
DOT Pitch	0.45(W) x 0.45(H)	mm
LCD Type	<input type="checkbox"/> TN, Positive <input type="checkbox"/> TN, Negative <input type="checkbox"/> HTN, Positive <input type="checkbox"/> HTN, Negative <input type="checkbox"/> STN, Yellow-Green <input type="checkbox"/> STN, Gray <input type="checkbox"/> STN, Blue <input type="checkbox"/> FSTN, Positive <input type="checkbox"/> FSTN, Negative <input type="checkbox"/> Color STN <input type="checkbox"/> FM LCD	
Polarizer Type	<input type="checkbox"/> Transmissive <input type="checkbox"/> Reflective <input type="checkbox"/> Transflective <input type="checkbox"/> Anti-Glare	
View Direction	<input type="checkbox"/> 6H <input type="checkbox"/> 12H <input type="checkbox"/> _____	
Operation Voltage	<input type="checkbox"/> 3.0(3.3) <input type="checkbox"/> 5.0 <input type="checkbox"/> _____	V
DC-DC Converter	<input checked="" type="checkbox"/> Build-in <input type="checkbox"/> External	
LCD Controller & Driver	T6963C & NT7086PQ	
LCD Driving Method	1/128duty, 1/12bias	
Interface Type	<input type="checkbox"/> 6800 <input checked="" type="checkbox"/> 8080 <input type="checkbox"/> I2C <input type="checkbox"/> Serial <input type="checkbox"/> SPI	
Backlight Type	<input type="checkbox"/> LED <input type="checkbox"/> CCFL <input type="checkbox"/> EL <input type="checkbox"/> no Backlight <input type="checkbox"/> _____	
Backlight Color	<input type="checkbox"/> Yellow-Green <input type="checkbox"/> White <input type="checkbox"/> Amber <input type="checkbox"/> Blue <input type="checkbox"/> Red <input type="checkbox"/> _____	
EL/CCFL Driver type	<input type="checkbox"/> Build-in <input type="checkbox"/> External	
Operation Temperature(oC)	-20-70 (TOPL – TOPH)	deg..
Storage Temperature (oC)	-30-80 (TSTL -- TSTH)	deg..

Note: Label “” means the option selected.

2. External Dimensions

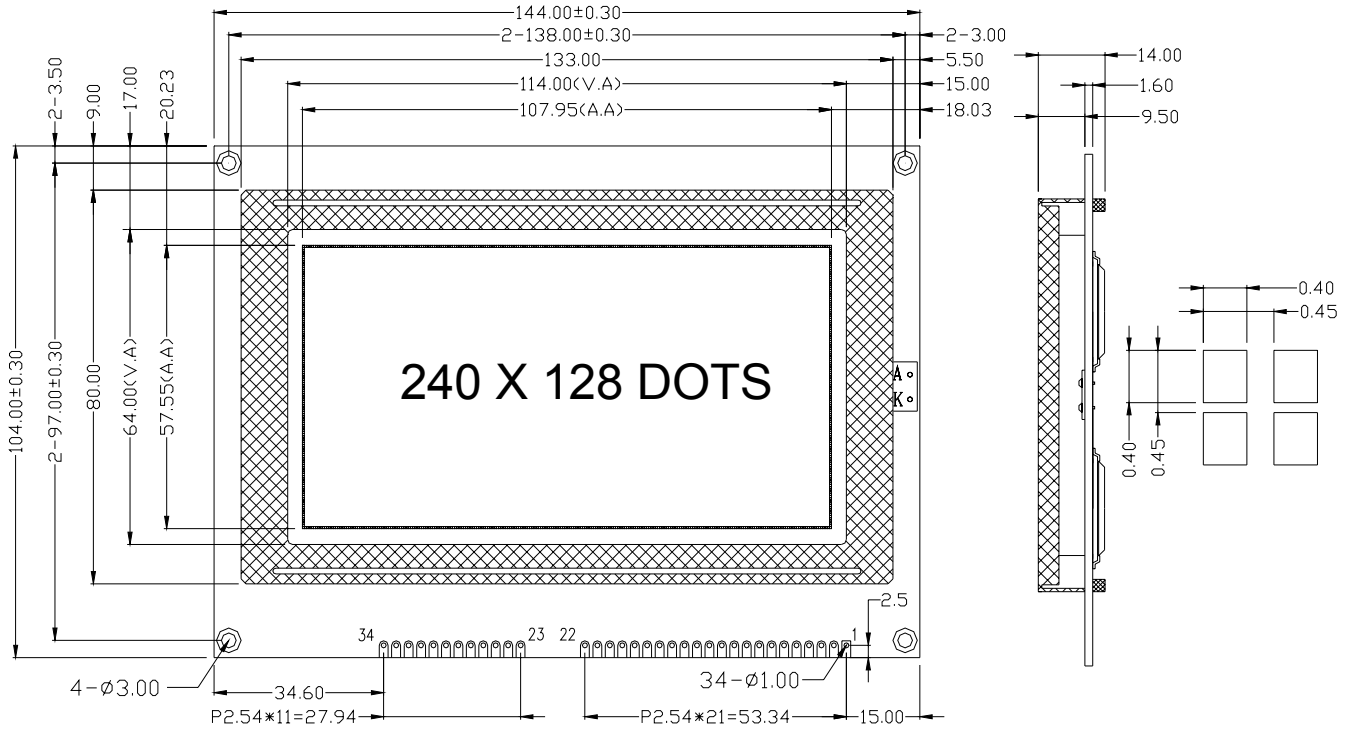

3. Block Diagram

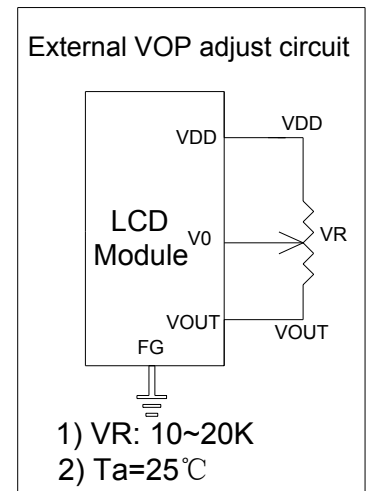
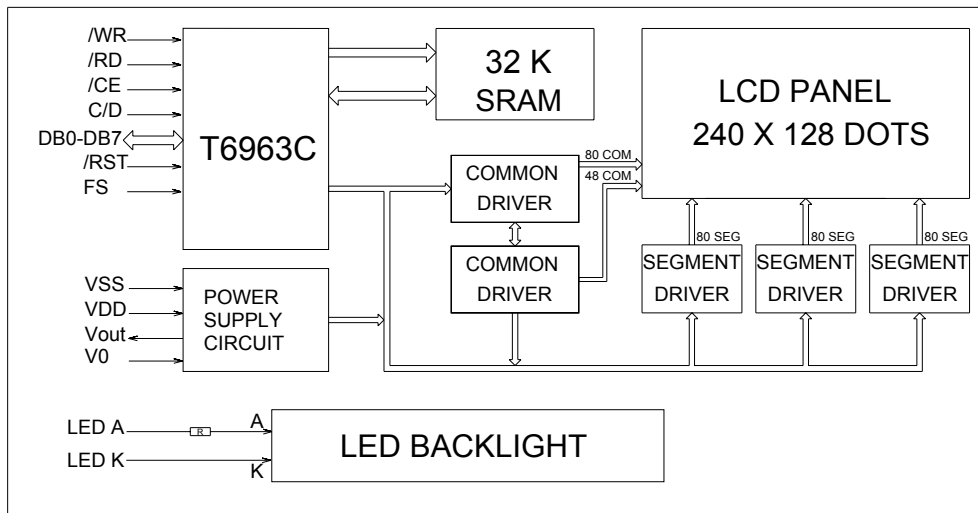



4. Pin Description

Pin.No	Symbol	Lever	Description
1	FG	P	Frame Ground.
2	VSS	P	GND.
3	VDD	P	Power supply for logic and LCD.
4	VO	P	Operating voltage for LCD.
5	/WR	I	Command and data write signal .
6	/RD	I	Data and status read signal.
7	/CE	I	Chip enable signal.
8	C/D	I	Command / Data selection.
9	NC	-	-
10	/RST	I	Reset signal(Low effective).
11-18	DB0-DB7	IO	Data bus.
19	FS	I	Selection of font H: 6 X 8 L: 8 X 8.
20	VEE		Negative voltage output to LCD.
21	A	P	Backlight anode (+5V).
22	K	P	Backlight cathode (+0V).
23	K	P	Backlight cathode (+0V).
24	A	P	Backlight anode (+5V).
25	VEE		Negative voltage output to LCD.
26	VO	P	Operating voltage for LCD.
27	VSS	P	GND.
28	VDD	P	Power supply for logic and LCD.
29	NC	-	-
30	HSCP		Shift clock pulse for column driver of upper area of LCD
31	LP		Latch pulse for column driver shift clock pulse for row driver
32	FR		Frame Signal
33	CDATA		Synchronous signal for row driver
34	ED		Sdsel:= H:Data output for even columns in both upper and lower areas of LCD Sdsel:= L:Data output for columns in both upper and lower lower areas of LCD

5. Optical Characteristics (VDD=5.0V, Ta = 25 °C)

Item	Symbol	Condition	Min	Type	Max	Unit	Remarks	Note
Contrast ratio	Cr	---	2	3	---	---	---	1
Viewing Angle	θ	Cr ≥ 2	35	---	---	deg	∅ = 90°	2
			35	---	---	deg	∅ = 270°	2
			50	---	---	deg	∅ = 0°	2
			33	---	---	deg	∅ = 180°	2

$$Cr = \frac{\text{Brightness of non-selected segment}(B2)}{\text{Brightness of selected segment}(B1)}$$

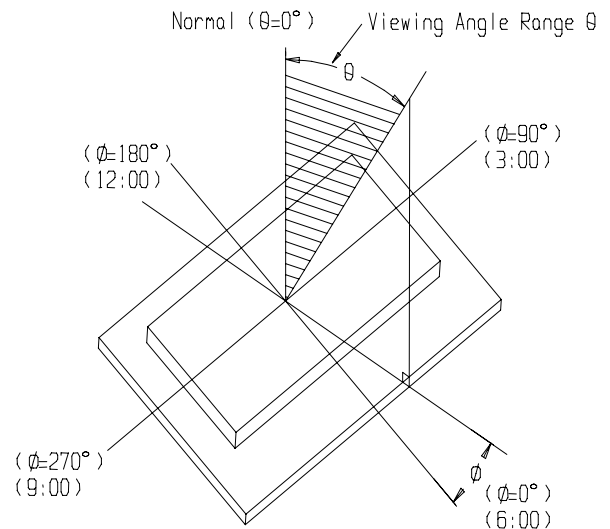
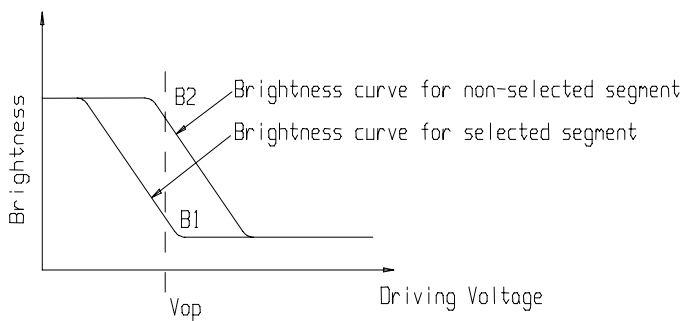

6. Electrical Characteristics (VSS = 0 V, VDD = 5.0 V ± 10%, Ta = -20 to 75°C)

Item	Symbol	Test Circuit	Test Condition	Min	Typ.	Max	Unit	Pin Name
Operating Voltage	VDD	-	-	4.5	5.0	5.5	V	VDD
Input	H Level	VIH	-	VDD-2.2	-	VDD	V	Input pins
	L Level	VIL	-	0	-	0.8	V	Input pins
Output Voltage	H Level	VOH	-	VDD-0.3	-	VDD	V	Output pins
	L Level	VOL	-	0	-	0.3	V	Output pins
Output Resistance	H Level	ROH	VOUT = VDD - 0.5 V	-	-	400	Ω	Output pins
	L Level	ROL	VOUT = 0.5 V	-	-	400	Ω	Output pins
Input Pull-up Resistance	RPU	-	-	50	100	200	KΩ	(Note 1)
Operating Frequency	fOSC	-	-	0.4	-	5.5	MHz	
Current Consumption (Operating)	IDD (1)	-	VDD = 5.0 V (Note 2) fOSC = 3.0 MHz	-	3.3	6	mA	VDD
Current Consumption (Halt)	IDD (2)	-	VDD=5.0V	-	-	3	μA	VDD

Note 1: Applied T1, T2, RESET

Note 2: MDS = L, MD0 = L, MD1 = L, MD2 = H, MD3 = H, FS0 = L, FS1 = L, SSEL = L, DUAL = H, D7 to D0 = LHLHLHLH

7. ABSOLUTE MAXIMUM RATINGS (Ta = 25°C)

Parameter	Symbol	Min	Max	Unit
Supply voltage for logic	Vdd	-0.3	5.5	V
Supply current	Idd	-	23	mA
Supply voltage for LED	Vled		5.0	V
Supply current for LED	Iled		180	mA
Operating temperature	Top	-10	55	°C
Storage temperature	Tst	-20	65	°C

*Note: Based on Vss=0V.

8. Timing Characteristics

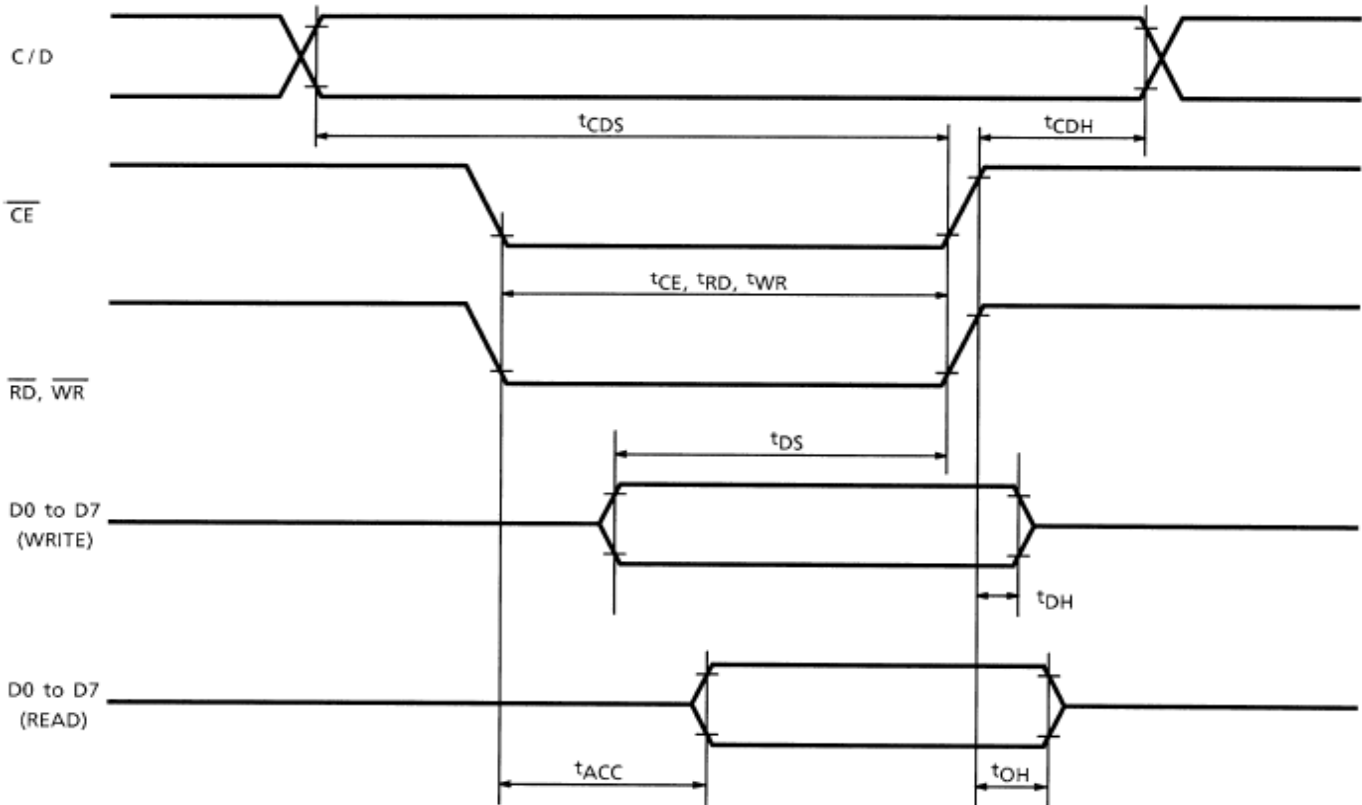

Test Conditions (Unless Otherwise Noted, VDD = 5.0 V ± 10%, VSS = 0 V, Ta = -20 to 75°C)

Item	Symbol	Test Conditions	Min	Max	Unit
C/D Set-up Time	tCDS	-	100	-	ns
C/D Hold Time	tCDH	-	10	-	ns
CE, RD, WR Pulse Width	tCE, tRD, tWR	-	80	-	ns
Data Set-up Time	tDS	-	80	-	ns
Data Hold Time	tDH	-	40	-	ns



Access Time	tACC	-	-	150	ns
Output Hold Time	tOH	-	10	50	ns

9. Instruction Table

Command	Code	D1	D2	Function
REGISTERS	00100001	X address	Y address	Set Cursor Pointer
	00100010	Data	00H	Set Offset Register
SETTING	00100100	Low address	High address	Set Address Pointer
SET CONTROL WORD	01000000	Low address	High address	Set Text Home Address
	01000001	Columns	00H	Set Text Area
	01000010	Low address	High address	Set Graphic Home Address
	01000011	Columns	00H	Set Graphic Area
MODE SET	1000X000	-	-	OR mode
	1000X001	-	-	EXOR mode
	1000X011	-	-	AND mode
	1000X100	-	-	Text Attribute mode
	10000XXX	-	-	Internal CG ROM mode
	10001XXX	-	-	External CG RAM mode
DISPLAY MODE	10010000	-	-	Display off
	1001XX10	-	-	Cursor on, blink off
	1001XX11	-	-	Cursor on, blink on
	100101XX	-	-	Text on, graphic off
	100110XX	-	-	Text off, graphic on
	100111XX	-	-	Text on, graphic on
CURSOR PATTERN SELECT	10100000	-	-	1-line cursor
	10100001	-	-	2-line cursor
	10100010	-	-	3-line cursor
	10100011	-	-	4-line cursor
	10100100	-	-	5-line cursor
	10100101	-	-	6-line cursor
	10100110	-	-	7-line cursor
	10100111	-	-	8-line cursor
DATA AUTO READ / WRITE	10110000	-	-	Set Data Auto Write
	10110001	-	-	Set Data Auto Read
	10110010	-	-	Auto Reset
DATA READ / WRITE	11000000	Data	-	Data Write and Increment ADP
	11000001	-	-	Data Read and Increment ADP
	11000010	Data	-	Data Write and Decrement ADP
	11000011	-	-	Data Read and Decrement ADP
	11000100	Data	-	Data Write and Nonvariable ADP
	11000101	-	-	Data Read and Nonvariable ADP
SCREEN PEEK	11100000	-	-	Screen Peek
SCREEN COPY	11101000	-	-	Screen Copy
BIT SET / RESET	11110XXX	-	-	Bit Reset
	11111XXX	-	-	Bit Set
	1111X000	-	-	Bit 0 (LSB)
	1111X001	-	-	Bit 1
	1111X010	-	-	Bit 2
	1111X011	-	-	Bit 3
	1111X100	-	-	Bit 4
	1111X101	-	-	Bit 5
	1111X110	-	-	Bit 6
	1111X111	-	-	Bit 7 (MSB)

See the "T6963C" data sheet of TOSHIBA to get more detail.



Character Code Map

MSB \ LSB	0	1	2	3	4	5	6	7	8	9	A	B	C	D	E	F
0		!	"	#	\$	%	&	'	()	*	+	,	-	.	/
1	0	1	2	3	4	5	6	7	8	9	:	;	<	=	>	?
2		A	B	C	D	E	F	G	H	I	J	K	L	M	N	O
3		P	Q	R	S	T	U	V	W	X	Y	Z	[\]	^
4		a	b	c	d	e	f	g	h	i	j	k	l	m	n	o
5		p	q	r	s	t	u	v	w	x	y	z	{		}	~
6		0	1	2	3	4	5	6	7	8	9	:	;	<	=	>
7																

10. Software Design Guide

```
//define shortcut variable
#define LCD_LEFT 0 //set 0 line beginning
#define LCD_TOP 0 //set 0 row beginning
#define LCD_RIGHT 239 //set 240 line
#define LCD_BOTTOM 127 //set 128 row
#define LCD_DELAY 0

/*****/
void lcd_init(void)
{
    LCD_RES_H;
    LCD_RES_L;
    lcd_delay(15);
    LCD_RES_H;

    Write_command3(0x40,0,0); //SET TXT HM ADD
    Write_command3(0x41,30,0); //SET TXT AREA
    Write_command3(0x42,0,0); //SET GR HM ADD
    Write_command3(0x43,30,0); //SET GR AREA
    Write_command(0x80); //MODE SET: OR MODE
    Write_command(0x98); //DISPLAY ON,GRAPHIC MODE
}

/*****Write command*****/
void Write_command(uchar lcd_code)
{
    LCD_DDR = 0X00;
    LCD_CODE_P &= ~(BIT(LCD_RD) | BIT(LCD_CE));
    while((LCD_DATA & 0X03) != 0X03);
    LCD_RD_H;
}
```



```

LCD_CD_H;    //LCD_CD_H=write command
LCD_RW_L;
LCD_DDR      = 0xFF;
LCD_PORT     = lcd_code;
LCD_CODE_P   |= (BIT(LCD_RW) | BIT(LCD_RD) | BIT(LCD_CD) | BIT(LCD_CE));
}

/*****Write data*****/
void Write_data(uchar lcd_data)
{
    LCD_DDR      = 0x00;
    LCD_CODE_P   &= ~(BIT(LCD_RD) | BIT(LCD_CE));
    while((LCD_DATA & 0x03) != 0x03);
    LCD_RD_H;
    LCD_CD_L;    //LCD_CD_H=write data
    LCD_RW_L;
    LCD_DDR      = 0xFF;
    LCD_PORT     = lcd_data;
    LCD_CODE_P   |= (BIT(LCD_RW) | BIT(LCD_RD) | BIT(LCD_CD) | BIT(LCD_CE));
}

/*****set address*****/
void Write_command3(uchar lcd_code,uchar lcd_data1,uchar lcd_data2)
{
    Write_data(lcd_data1);
    Write_data(lcd_data2);
    Write_command(lcd_code);
}

/*****Clear Screen*****/
void ClearScreen()
{
    unsigned int i;
    //clear RAM area 0000h-2000h (8k)
    Write_command3(0x00,0x00,0x24); //set 0000H beginning

    Write_command(0xb0); //set auto write mode
    for(i=0x00;i<0x2000;i++)
    {
        OutPortData(0x00); // write data=0;
    }
    Write_command(0xb2); // auto write end
}

```

11. PRECAUTIONS FOR USING LCD MODULES

Handling Precautions

- (1) The display panel is made of glass. Do not subject it to a mechanical shock by dropping it or impact.
- (2) If the display panel is damaged and the liquid crystal substance leaks out, be sure not to get any in your mouth. If the substance contacts your skin or clothes, wash it off using soap and water.
- (3) Do not apply excessive force to the display surface or the adjoining areas since this may cause the color tone to vary.
- (4) The polarizer covering the display surface of the LCD module is soft and easily scratched. Handle this polarizer carefully.



(5) If the display surface becomes contaminated, breathe on the surface and gently wipe it with a soft dry cloth. If it is heavily contaminated, moisten cloth with one of the following solvents :

- Isopropyl alcohol
- Ethyl alcohol

(6) Solvents other than those above-mentioned may damage the polarizer. Especially, do not use the following.

- Water
- Ketone
- Aromatic solvents

(7) Exercise care to minimize corrosion of the electrode. Corrosion of the electrodes is accelerated by water droplets, moisture condensation or a current flow in a high-humidity environment.

(8) Install the LCD Module by using the mounting holes. When mounting the LCD module make sure it is free of twisting, warping and distortion. In particular, do not forcibly pull or bend the I/O cable or the backlight cable.

(9) Do not attempt to disassemble or process the LCD module.

(10) NC terminal should be open. Do not connect anything.

(11) If the logic circuit power is off, do not apply the input signals.

(12) To prevent destruction of the elements by static electricity, be careful to maintain an optimum work environment.

- Be sure to ground the body when handling the LCD modules.
- Tools required for assembling, such as soldering irons, must be properly grounded.
- To reduce the amount of static electricity generated, do not conduct assembling and other work under dry conditions.

- The LCD module is coated with a film to protect the display surface. Exercise care when peeling off this protective film since static electricity may be generated.

Storage Precautions

When storing the LCD modules, avoid exposure to direct sunlight or to the light of fluorescent lamps. Keep the modules in bags (avoid high temperature / high humidity and low temperatures below 0°C). Whenever possible, the LCD modules should be stored in the same conditions in which they were shipped from our company.

Others

Liquid crystals solidify under low temperature (below the storage temperature range) leading to defective orientation or the generation of air bubbles (black or white). Air bubbles may also be generated if the module is subject to a low temperature.

If the LCD modules have been operating for a long time showing the same display patterns, the display patterns may remain on the screen as ghost images and a slight contrast irregularity may also appear. A normal operating status can be regained by suspending use for some time. It should be noted that this phenomenon does not adversely affect performance reliability.

To minimize the performance degradation of the LCD modules resulting from destruction caused by static electricity etc., exercise care to avoid holding the following sections when handling the modules.

- Exposed area of the printed circuit board.
- Terminal electrode sections.

12. USING LCD MODULES

Liquid Crystal Display Modules

LCD is composed of glass and polarizer. Pay attention to the following items when handling.

(1) Please keep the temperature within specified range for use and storage. Polarization degradation, bubble generation or polarizer peel-off may occur with high temperature and high humidity.

(2) Do not touch, push or rub the exposed polarizers with anything harder than an HB pencil lead (glass, tweezers, etc.).

(3) N-hexane is recommended for cleaning the adhesives used to attach front/rear polarizers and reflectors made of organic substances which will be damaged by chemicals such as acetone, toluene, ethanol and isopropylalcohol.

(4) When the display surface becomes dusty, wipe gently with absorbent cotton or other soft material like chamois soaked in petroleum benzine. Do not scrub hard to avoid damaging the display surface.

(5) Wipe off saliva or water drops immediately, contact with water over a long period of time may cause deformation or color fading.

(6) Avoid contacting oil and fats.

(7) Condensation on the surface and contact with terminals due to cold will damage, stain or dirty the polarizers. After products are tested at low temperature they must be warmed up in a container before coming in contact with room temperature air.

(8) Do not put or attach anything on the display area to avoid leaving marks on.

(9) Do not touch the display with bare hands. This will stain the display area and degrade insulation between terminals (some cosmetics are detrimental to the polarizers).

(10) As glass is fragile. It tends to become chipped during handling especially on the edges. Please avoid dropping or jarring.

Installing LCD Modules

The hole in the printed circuit board is used to fix LCM as shown in the picture below. Attend to the following items when installing the LCM.

(1) Cover the surface with a transparent protective plate to protect the polarizer and LC cell.

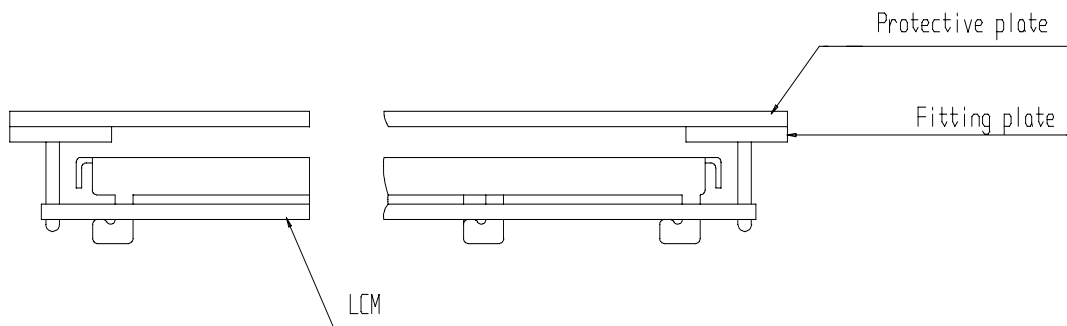

(2) When assembling the LCM into other equipment, the spacer to the bit between the LCM and the fitting plate should have enough height to avoid causing stress to the module surface, refer to the individual specifications for measurements. The measurement tolerance should be ± 0.1 mm.

Precaution for Handling LCD Modules

Since LCM has been assembled and adjusted with a high degree of precision, avoid applying excessive shocks to the module or making any alterations or modifications to it.

(1) Do not alter, modify or change the shape of the tab on the metal frame.

(2) Do not make extra holes on the printed circuit board, modify its shape or change the positions of components to be attached.

(3) Do not damage or modify the pattern writing on the printed circuit board.

(4) Absolutely do not modify the zebra rubber strip (conductive rubber) or heat seal connector.

(5) Except for soldering the interface, do not make any alterations or modifications with a soldering iron.

(6) Do not drop, bend or twist LCM.

(7) In order to avoid the cracking of the FPC, you should pay attention to the area of FPC (R50mm) where the FPC was bent. The edge of coverlay; the area of surface of Ni-Au plating, the area of soldering land, the area of through hole.

Electro-Static Discharge Control

Since this module uses a CMOS LSI, the same careful attention should be paid to electrostatic discharge as for an ordinary CMOS IC.

(1) Make certain that you are grounded when handling LCM.

(2) Before remove LCM from its packing case or incorporating it into a set, be sure the module and your body have the same electric potential.

(3) When soldering the terminal of LCM, make certain the AC power source for the soldering iron does not leak.



(4) When using an electric screwdriver to attach LCM, the screwdriver should be of ground potential to minimize as much as possible any transmission of electromagnetic waves produced sparks coming from the commutator of the motor.

(5) As far as possible make the electric potential of your work clothes and that of the work bench the ground potential.

(6) To reduce the generation of static electricity be careful that the air in the work is not too dried. A relative humidity of 50%-60% is recommended.

Precaution for soldering to the LCM

(1) Observe the following when soldering lead wire, connector cable and etc. to the LCM.

- Soldering iron temperature : $260^{\circ}\text{C} \pm 10^{\circ}\text{C}$.
- Soldering time : 3-4 sec.
- Solder : eutectic solder.

If soldering flux is used, be sure to remove any remaining flux after finishing to soldering operation. (This does not apply in the case of a non-halogen type of flux.) It is recommended that you protect the LCD surface with a cover during soldering to prevent any damage due to flux spatters.

(2) When soldering the electroluminescent panel and PC board, the panel and board should not be detached more than three times. This maximum number is determined by the temperature and time conditions mentioned above, though there may be some variance depending on the temperature of the soldering iron.

(3) When remove the electroluminescent panel from the PC board, be sure the solder has completely melted, the soldered pad on the PC board could be damaged.

(4) Soldering iron is not allowed to touch the surface of FPC's cover film directly.

Precautions for Operation

(1) Viewing angle varies with the change of liquid crystal driving voltage (VO). Adjust VO to show the best contrast.

(2) Driving the LCD in the voltage above the limit shortens its life.

(3) Response time is greatly delayed at temperature below the operating temperature range. However, this does not mean the LCD will be out of the order. It will recover when it returns to the specified temperature range.

(4) If the display area is pushed hard during operation, the display will become abnormal. However, it will return to normal if it is turned off and then back on.

(5) Condensation on terminals can cause an electrochemical reaction disrupting the terminal circuit. Therefore, it must be used under the relative condition of 40°C , 50% RH.

(6) When turning the power on, input each signal after the positive/negative voltage becomes stable.

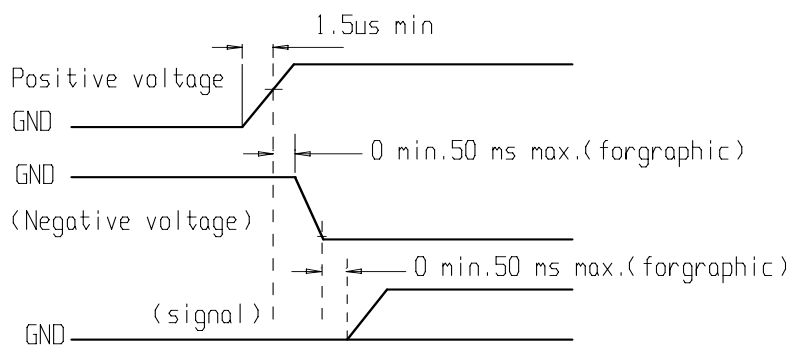

Storage

When storing LCDs as spares for some years, the following precaution are necessary.

(1) Store them in a sealed polyethylene bag. If properly sealed, there is no need for dessicant.

(2) Store them in a dark place. Do not expose to sunlight or fluorescent light, keep the temperature between 0°C and 35°C .

(3) The polarizer surface should not come in contact with any other objects. (We advise you to store them in the container in which they were shipped.)

(4) Environmental conditions :

- Do not leave them for more than 160hrs. at 70°C .



- Should not be left for more than 48hrs. at -20°C.

Safety

(1) It is recommended to crush damaged or unnecessary LCDs into pieces and wash them off with solvents such as acetone and ethanol, which should later be burned.

(2) If any liquid leaks out of a damaged glass cell and comes in contact with the hands, wash off thoroughly with soap and water.

Limited Warranty

Unless agreed between EAST and customer, EAST will replace or repair any of its LCD modules which are found to be functionally defective when inspected in accordance with EAST LCD acceptance standards (copies available upon request) for a period of one year from date of shipments. Cosmetic/visual defects must be returned to EAST within 90 days of shipment. Confirmation of such date shall be based on freight documents. The warranty liability of EAST limited to repair and/or replacement on the terms set forth above. EAST will not be responsible for any subsequent or consequential events.

Return LCM under warranty

No warranty can be granted if the precautions stated above have been disregarded. The typical examples of violations are :

- Broken LCD glass.
- PCB eyelet's damaged or modified.
- PCB conductors damaged.
- Circuit modified in any way, including addition of components.
- PCB tampered with by grinding, engraving or painting varnish.
- soldering to or modifying the bezel in any manner.

Module repairs will be invoiced to the customer upon mutual agreement. Modules must be returned with sufficient description of the failures or defects. Any connectors or cable installed by the customer must be removed completely without damaging the PCB's eyelet, conductors and terminals.