



PRODUCT SPECIFICATION FOR LCD MODULE

MODULE NO. : ET-G12232A
REVERSION : V2
TYPE : COB

Customer Approval:

--	--	--	--

PREPARED BY		DATE	
CHECKED BY		DATE	
APPROVED BY		DATE	



1. General Specifications

Item	Standard Value	Unit
Number of dots	122(W)X32(H)	dots
Display Pattern	<input checked="" type="checkbox"/> Dot-Graphic <input type="checkbox"/> Character <input type="checkbox"/> Digits <input type="checkbox"/> with ICON <input type="checkbox"/> _____	
Module Dimension	84.0(W) X44.0(H) X 13.5(T)	mm
Viewing Area	59.8(W) X 17.8(H)	mm
Active Area	48.76(W) x 15.32(H)	mm
DOT Size	0.36(W) x 0.41(H)	mm
DOT Pitch	0.40(W) x 0.45(H)	mm
LCD Type	<input type="checkbox"/> TN, Positive <input type="checkbox"/> TN, Negative <input type="checkbox"/> HTN, Positive <input type="checkbox"/> HTN, Negative <input type="checkbox"/> STN, Yellow-Green <input type="checkbox"/> STN, Gray <input type="checkbox"/> STN, Blue <input type="checkbox"/> FSTN, Positive <input type="checkbox"/> FSTN, Negative <input type="checkbox"/> Color STN <input type="checkbox"/> FM LCD	
Polarizer Type	<input type="checkbox"/> Transmissive <input type="checkbox"/> Reflective <input type="checkbox"/> Transflective <input type="checkbox"/> Anti-Glare	
View Direction	<input type="checkbox"/> 6 <input type="checkbox"/> 12 <input type="checkbox"/> _____	H
Operation Voltage	<input type="checkbox"/> 3.0(3.3) <input type="checkbox"/> 5.0 <input type="checkbox"/> _____	V
DC-DC Converter	<input type="checkbox"/> Build-in <input type="checkbox"/> External	
LCD Controller & Driver	SED1520	
LCD Driving Method	1/32duty, 1/5bias	
Interface Type	<input checked="" type="checkbox"/> 6800 <input checked="" type="checkbox"/> 8080 <input type="checkbox"/> I2C <input type="checkbox"/> Serial <input type="checkbox"/> SPI	
Backlight Type	<input checked="" type="checkbox"/> LED <input type="checkbox"/> CCFL <input type="checkbox"/> EL <input type="checkbox"/> no Backlight <input type="checkbox"/> _____	
Backlight Color	<input type="checkbox"/> Yellow-Green <input type="checkbox"/> White <input type="checkbox"/> Amber <input type="checkbox"/> Blue <input type="checkbox"/> Red <input type="checkbox"/> _____	
EL/CCFL Driver type	<input type="checkbox"/> Build-in <input type="checkbox"/> External	
Operation Temperature(oC)	-20~70 (TOPL – TOPH)	deg..
Storage Temperature (oC)	-30~80 (TSTL -- TSTH)	deg..

Note: Label “” means the option selected.



2. External Dimensions

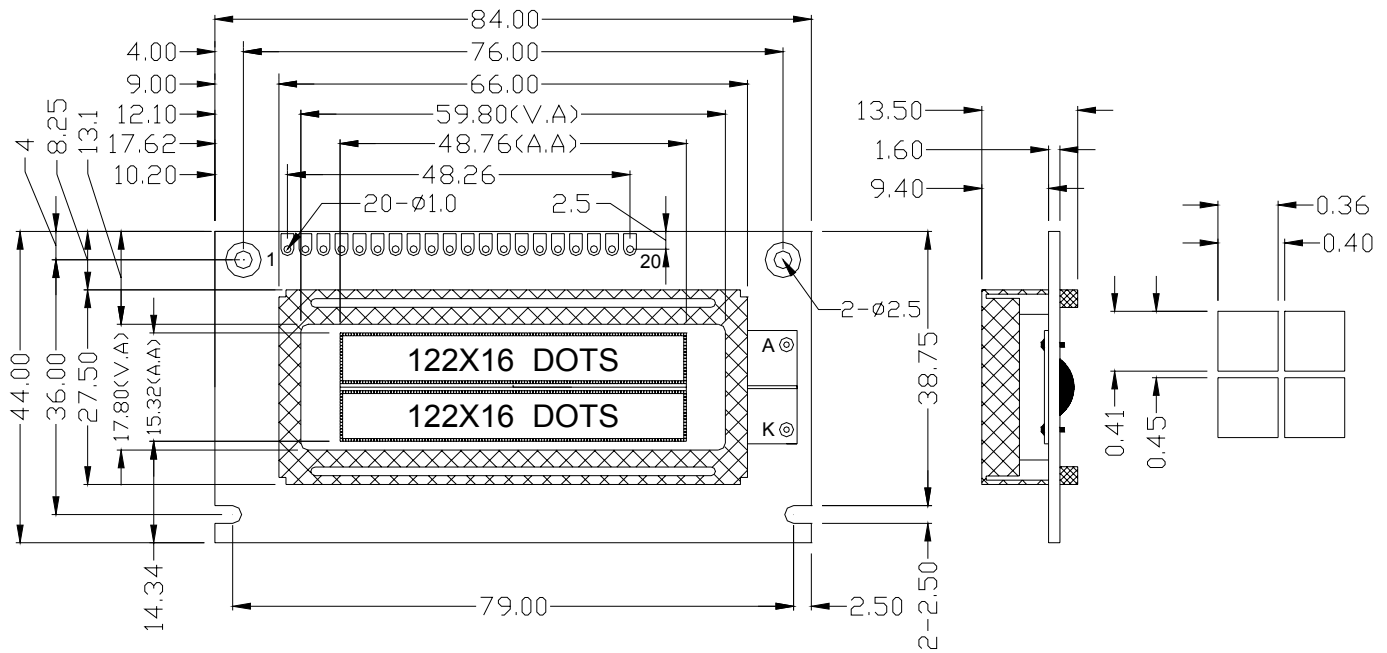

3. Block Diagram

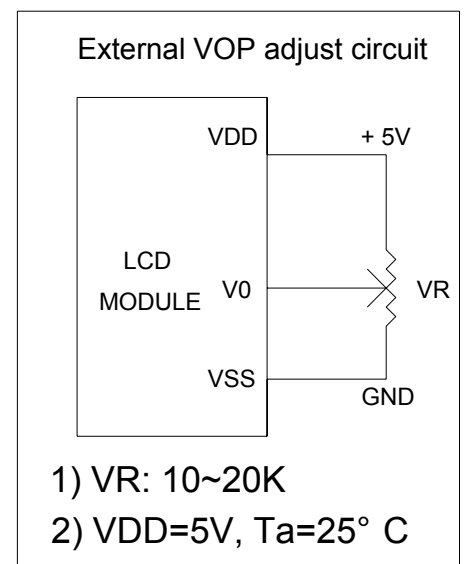
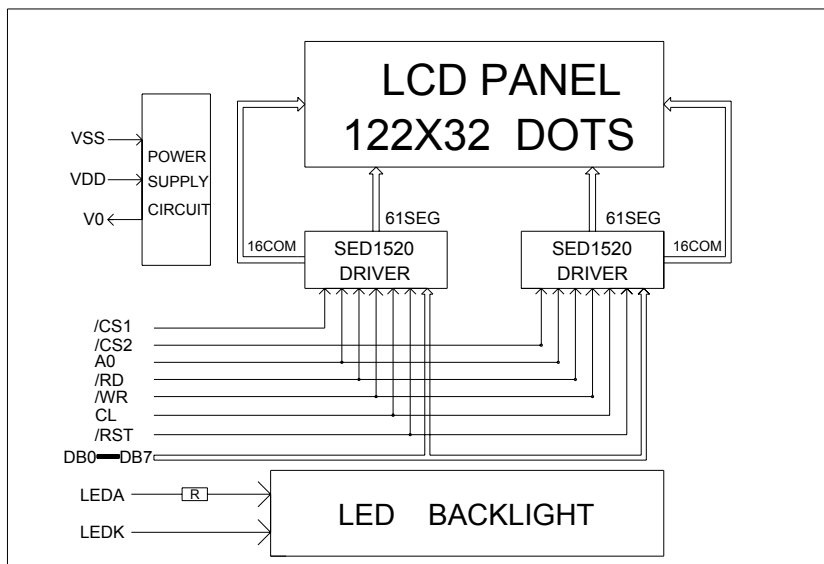



4. Pin Description

Pin.No	Symbol	Lever	Description
1	VSS	P	GND.
2	VDD	P	Power supply for logic and LCD.
3	V0	P	Operating voltage for LCD.
4	A0	I	Data/Instruction Select .
5	/CS1	I	Read/Write Enable Signal U1.
6	/CS2	I	Read/Write Enable Signal U2.
7	CL	I	Clock input.
8	/RD	I	Read Enable signal. (Low Active).
9	/WR	I	Write Enable Signal. (Low Active).
10-17	DB0-DB7	I/O	Data bus.
18	/RST	I	Low lever for reset.
19	A	P	Backlight anode (+5V).
20	K	P	Backlight cathode (0V).

5. DC Characteristics (Based on Ta = -0 to 50 deg. C, Vss = 0 V)

Item	Symbol	Min	Type	Max	Unit	Applicable terminal	Test condition
Operating voltage	V _{DD}	4.7	5.0	5.2	V	-	--
Supply current	I _{DD}	-	1.5	2.0	mA	V _{DD}	During display
Supply backlight voltage	V _{led}	4.8	5.0	5.5	V	K	Turn on LED
Input backlight current	I _{led}	120	140	180	mA	K	Turn on LED
Input voltage	V _{IL}	VSS	-	0.8	V	RS,R/W,/RST ,E,DB0~DB7	-
	V _{IH}	2.0	-	VDD	V		
Oscillator Frequency	f _{BOSCB}	15	18	21	KHZ		R _{BfB} = 1MΩ±2%
Reset Time	t _R	1.0	-	1000	μ s	/RST	

6. AC Timing Characteristics

6.1 System Bus Read/Write I (80 Family MPU)

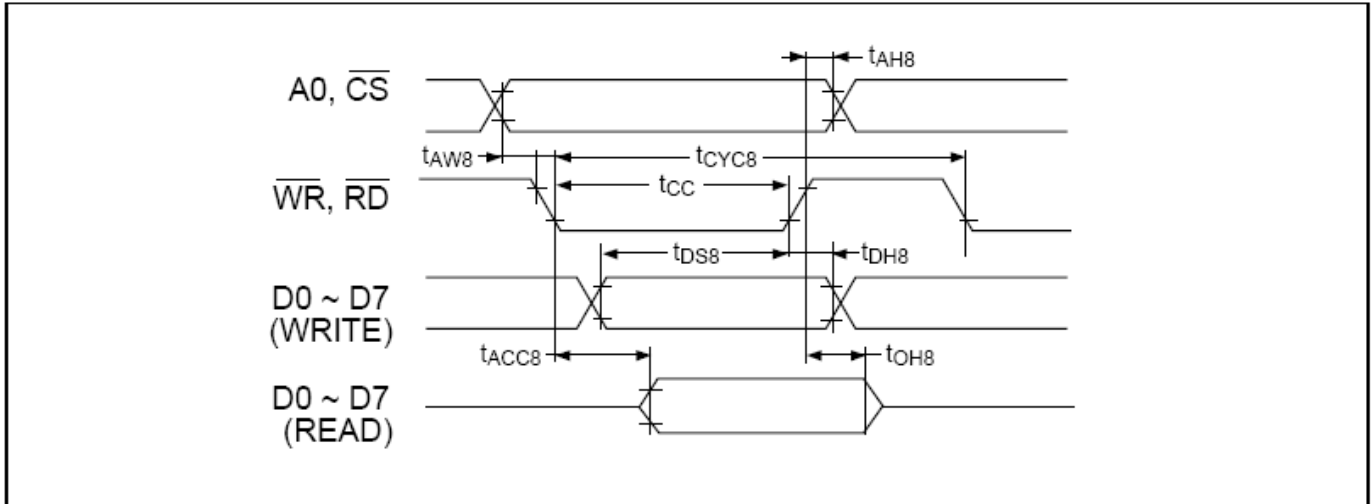

Ta = -0 to 50°C, VSS = -5.0V ± 10%, Unit: ns

Signal	Symbol	Parameter	Min.	Max.	Condition
A0, /CS	t AH8	Address hold time	10		
	t AW8	Address setup time	20		
/WR, /RD	t CYC8	System cycle time	1000		
	t CC	Control pulse width	200		
D0-D7	t DS8	Data setup time	80		
	t DH8	Data hold time	10		
	t ACC8	/RD access time		90	
	t OH8	Output disable time	10	60	

- Each of the values where Vss = -3.0V is about 200% of that where Vss = -5.0V
- The rise or fall time of input signals should be less than 15 ns.

6.2 System Bus Read/Write II (68 Family MPU)

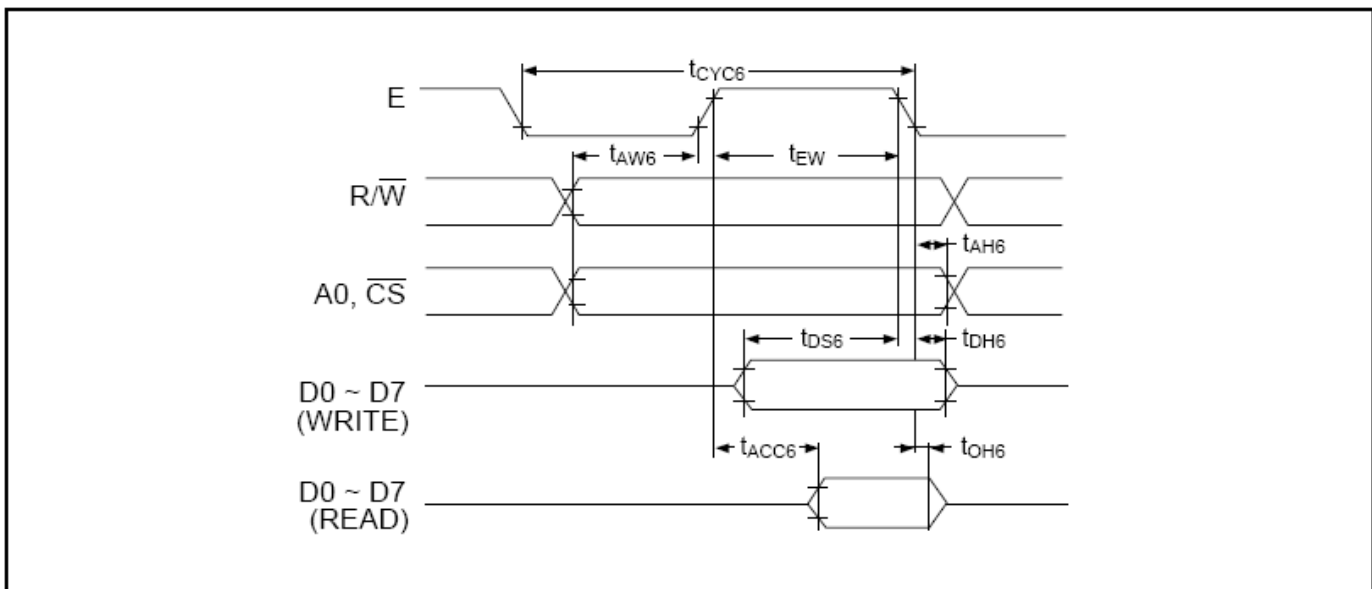

Ta = -0 to 50°C, VSS = -5.0V ± 10%, Unit: ns

Signal	Symbol	Parameter	Min.	Max.	Condition
A0, /CS	t CYC6*1	System cycle time	1000		



R/W	t _{AW6}	Address setup time	20		
	t _{AH6}	Address hold time	10		
D0-D7	t _{DS6}	Data setup time	80		
	t _{DH6}	Data hold time	10		
	t _{OH6}	Output disable time	10	60	
	t _{ACC6}	Access time		90	CL = 100pF
E	t _{EW}	Enable pulse width Read	100		
		Enable pulse width Write	80		

1. t_{CYC6} indicates the cycle time during which CS•E = "H". It does not mean the cycle time of signal E.
2. Each of the values where V_{SS} = -3.0V is about 200% of that where V_{SS} = -5.0V (i.e., the listed value).
3. The rise or fall time of input signals should be less than 15 ns.

7. Optical Characteristics (V_{DD}=5.0V, T_a = 23 °C)

Item	Symbol	Condition	Min	Type	Max	Unit	Remarks	Note
Contrast ratio	Cr	V _{LCD} = Typ. *	---	3.76	---	---	---	1
Response time	T _{on}	---	---	270	---	ms	---	2
Response time	T _{off}	---	---	45	---	ms	---	3
Viewing Angle	θ	Cr ≥ 2	24	---	---	deg	6H, ∅ = 90°	4
			51	---	---	deg	12H, ∅ = 270°	5
			50	---	---	deg	3H, ∅ = 0°	6
			50	---	---	deg	9H, ∅ = 180°	7

Note:

V_{LCD} can be found in 4.2 DC Characteristics *Supply Voltage for LCD Driver*

8. Instruction Table

	Command	Code										Function	
		A0	RD	WR	D7	D6	D5	D4	D3	D2	D1		D0
(1)	Display ON/OFF	0	1	0	1	0	1	0	1	1	1	0/1	Turns all display on or off, independently of display RAM data or internal status. 1:ON 0:OFF(Power-saving mode with static drive on)*
(2)	Display start line	0	1	0	1	1	0	Display Start address(0-31)				Specifies RAM line corresponding To uppermost line(COMO)of display	
(3)	Set page address	0	1	0	1	0	1	1	1	0	Page(0-3)		Sets display RAM column address in page address register
(4)	Set column (segment) address	0	1	0	0	Column Address(0-79)					Sets display RAM column address in column address register		



(5)	Read status	0	0	1	Busy	ADC	ON/OFF	RESET	0	0	0	0	Reads the following status: BUSY 1:Internal operation,0:Ready ADC 1:CW output(forward), 0:CCW output(reverse) ON/OFF 1:Display off,0:Display on RESET 1:Being reset,0:Normal
(6)	Write display data	1	1	0	Write Data							Writes data from Data bus into Display RAM .	Display RAM Location whose Address has Been preset is Accessed.After Access,the Column address Is incremented By 1.
(7)	Read display data	1	0	1	Read Data							Reads data from Display RAM onto Data bus .	
(8)	Select ADC	0	1	0	1	0	1	0	0	0	0	0/1	Used to invert relationship of Assignment between display RAM Column addresses and segment driver Outputs. 0:CW output(forward) 1:CCW output(reverse)
(9)	Staticdrive ON/OFF	0	1	0	1	0	1	0	0	1	0	0/1	Selects normal display or static Driveng operation. 1:Static drive(power-saving mode) 0:Normal driving
(10)	Select duty	0	1	0	1	0	1	0	1	0	0	0/1	Selects LCD cell driving duty. 1:1/32 0:1/16
(11)	Read modify write	0	1	0	1	1	1	0	0	0	0	0	Increments column address counter By 1 when display data is written .(This is not done when data is read.)
(12)	End	0	1	0	1	1	1	0	1	1	1	0	Clears read modify write mode.
(13)	Reset	0	1	0	1	1	1	0	0	0	1	0	Sets display start line register on The first line.Also sets column Address counter and page address Counter to 0.

* With display off (command (1)), static drive going on (9) invokes power-saving mode.

9. Instruction Description

9.1 DISPLAY ON/OFF

RS	E	R/W	D7	D6	D5	D4	D3	D2	D1	D0
0	1	0	1	0	1	0	1	1	1	D

D=0 : Display OFF

D=1 : Display ON

9.2 DISPLAY START LINE

RS	E	R/W	D7	D6	D5	D4	D3	D2	D1	D0
0	1	0	1	1	0	A4	A3	A2	A1	A0

This command specifies a line address thus marking the display line that corresponds to COM0. Display begins with the specified line address and covers as many lines as match the display duty in address ascending order. Dynamic line address change with the Display Start Line command enables column-wise scrolling or page change.

A4	A3	A2	A1	A0	Line address
0	0	0	0	0	0
0	0	0	0	1	1



--					--
--					--
1	1	1	1	1	31

9.3 SET PAGE ADDRESS

RS	E	R/W	D7	D6	D5	D4	D3	D2	D1	D0
0	1	0	1	0	1	1	1	0	A1	A0

This command is used to specify a page address equivalent to a row address for MPU access to the display data RAM. A required bit of the display data RAM can be accessed by specifying its page address and column address. Changing the page address causes no change in display.

A1	A0	Page
0	0	0
0	1	1
1	0	2
1	1	3

9.4 COLUMN ADDRESS

RS	E	R/W	D7	D6	D5	D4	D3	D2	D1	D0
0	1	0	0	A6	A5	A4	A3	A2	A1	A0

This command specifies a display data RAM column address. The column address is incremented by 1 each time the MPU accesses from the set address to the display data RAM. Thus, it is possible for the MPU to gain continuous access to only the data. This incrementing stops with address 80; the page address is not continuously changed.

A6	A5	A4	A3	A2	A1	A0	Column address
0	0	0	0	0	0	0	0
0	0	0	0	0	0	1	1
--							--
--							--
1	0	0	1	1	1	1	79

9.5 READ STATUS

RS	E	R/W	D7	D6	D5	D4	D3	D2	D1	D0
0	0	1	Busy	ADC	ON/OFF	Reset	0	0	0	0

BUSY: BUSY being "1" means that system is performing an internal operation or is reset. No command is accepted before BUSY = "0". As long as the cycle time requirement is met, no BUSY check is needed.

ADC: Indicates assignment of column addresses to segment drivers.

0: Inverted (column address 79-n ↔ segment driver n)

1: Forward (column address n ↔ segment driver n)

ON/OFF: Indicates display on or off.

0: Display on

1: Display off

This bit has polarity reverse to the Display ON/OFF command.



RESET: Indicates that system is being initialized by the /RST signal or the Reset command.

0: Display mode

1: Being reset

9.6 WRITE DISPLAY DATA

RS	E	R/W	D7	D6	D5	D4	D3	D2	D1	D0
1	1	0	Write data							

This command allows the MPU to write 8 bits of data into the display data RAM. Once the data is written, the column address is automatically incremented by 1; this enables the MPU to write multiword data continuously.

9.7 READ DISPLAY DATA

RS	E	R/W	D7	D6	D5	D4	D3	D2	D1	D0
1	0	1	Read data							

This command allows the MPU to read 8 bits of data from the display data RAM location specified by a column address and a page address. Once the data is read, the column address is automatically incremented by 1; this enables the MPU to read multi-word data continuously.

A dummy read is needed immediately after the column address is set.

9.8 SELECT ADC

RS	E	R/W	D7	D6	D5	D4	D3	D2	D1	D0
0	1	0	1	0	1	0	0	0	0	D

This command inverts the relation of assignment between display data RAM column addresses and segment driver outputs. In other words, the Select ADC command can software-invert the order of segment driver output pins, reducing the restrictions on the configuration of ICs at LCD module assembly. Incrementing the column address by 1, which takes place after the MPU writing or reading display data, follows the sequence of column addresses

D = 0: Clockwise output (forward)

D = 1: Counterclockwise output (reverse)

9.9 STATIC DRIVE ON/OFF

RS	E	R/W	D7	D6	D5	D4	D3	D2	D1	D0
0	1	0	1	0	1	0	0	1	0	D

This command forces all display to be on and, at the same time, all common output to be selected

D = 0: Static drive off

D = 1: Static drive on

9.10 SELECT DUTY

RS	E	R/W	D7	D6	D5	D4	D3	D2	D1	D0
0	1	0	1	0	1	0	1	0	0	D



This command is used to select the duty (degree of multiplexity) of LCD driving.

D = 0: Duty 1/16

D = 1: Duty 1/32

9.11 READ MODIFY WRITE

RS	E	R/W	D7	D6	D5	D4	D3	D2	D1	D0
0	1	0	1	1	1	0	0	0	0	0

This command is used with the End command in a pair. Once it has been entered, the column address will be incremented not by the Read Display Data command but by the Write Display Data command only. This mode will stay until the End command is entered.

Entry of the End command causes the column address to return to the address which was valid when the Read Modify Write command was entered. This function lessens the load of the MPU when the data in a specific display area are repeatedly updated (as blinking cursor).

Even in the Read Modify Write mode, any command other than Read/Write Data and Set Column Address may be used.

Cursor Blinking Sequence

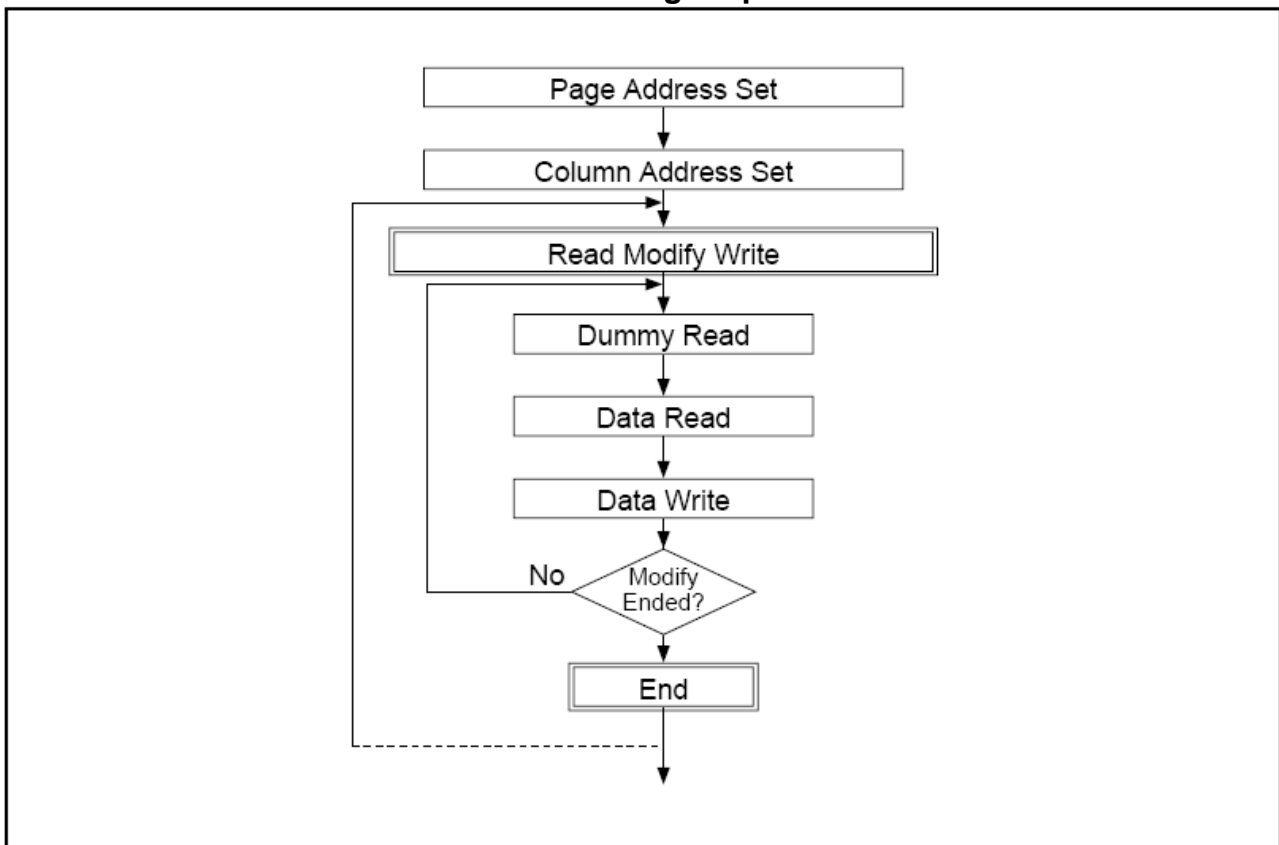

9.12 END

RS	E	R/W	D7	D6	D5	D4	D3	D2	D1	D0
0	1	0	1	1	1	0	1	1	1	0

This command cancels the Read Modify Write command, returning the column address to the initial mode address.



End Timing

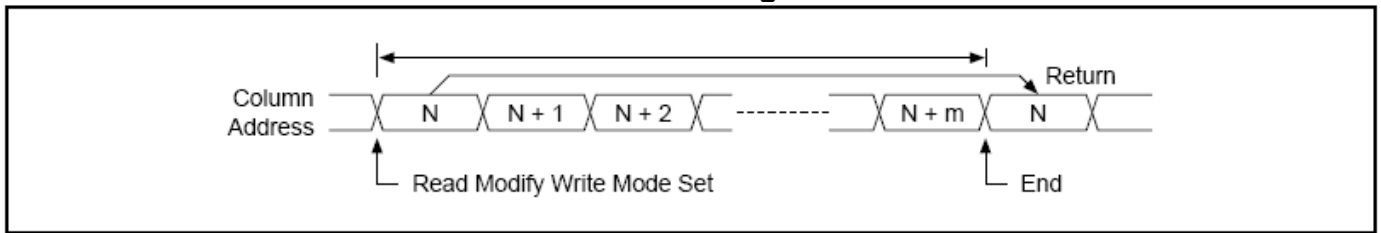

9.13 RESET

RS	E	R/W	D7	D6	D5	D4	D3	D2	D1	D0
0	1	0	1	1	1	0	0	0	1	0

This command initializes the display start line register, column address counter, and page address counter without any effect on the display data RAM.

The reset operation follows entry of the Reset command.

Initialization at power-on is performed not by the Reset command but by a reset signal applied to the /RST pin.

Relationship between Display Data RAM Locations and Addresses (Display Start Line: 08)

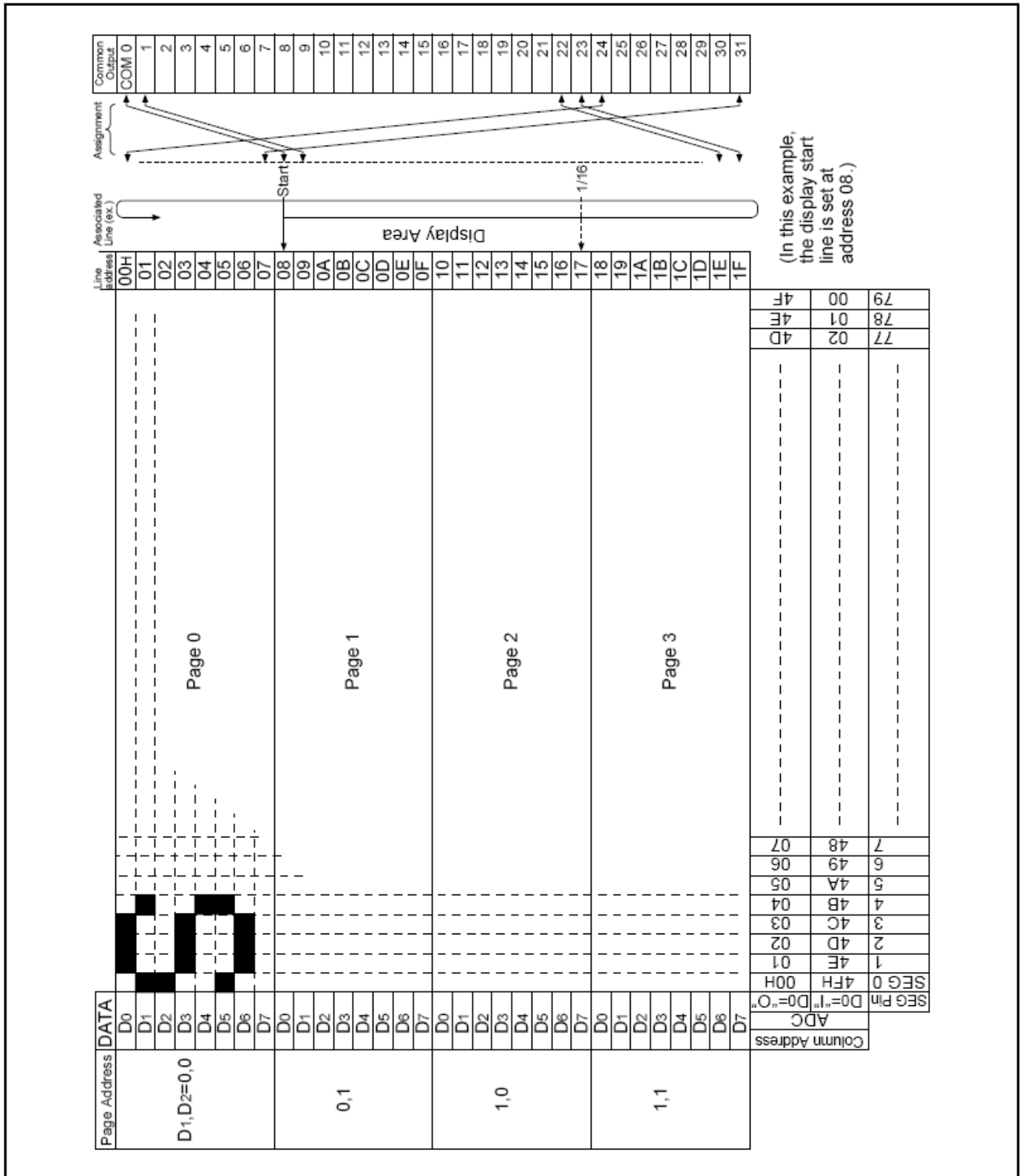

10. Software Design Guide

```
// test code for reference
// MCU: W78E516B
//Driver IC: SED1520
#define LCD_DISPLAYON 0xaf
#define LCD_DISPLAYOFF 0xae
#define LCD_DRIVERON 0xa5
```



```

#define LCD_DRIVEROFF 0xa4
#define LCD_DUTY16 0xa8
#define LCD_DUTY32 0xa9
#define LCD_END 0xee
#define LCD_RESET 0xe2
#define LCD_RWMODE 0xe0
#define LCD_STARTLINE0 0xc0 //c0-df
#define LCD_PAGE0 0xb8 //b8-bb
#define LCD_COLUMNADDR0 0x00

#define LCD_ON() LCD_Command(LCD_DISPLAYON)
#define LCD_OFF() LCD_Command(LCD_DISPLAYOFF)
#define LCD_StaticON() LCD_Command(LCD_DRIVERON)
#define LCD_StaticOFF() LCD_Command(LCD_DRIVEROFF)
#define LCD_Select16() LCD_Command(LCD_DUTY16)
#define LCD_Select32() LCD_Command(LCD_DUTY32)
#define LCD_StartRW() LCD_Command(LCD_RWMODE)
#define LCD_EndRW() LCD_Command(LCD_END)
#define LCD_Reset() LCD_Command(LCD_RESET)
#define LCD_SetStartLine(i) LCD_Command(LCD_STARTLINE0+i)
#define LCD_SetPage(i) LCD_Command(LCD_PAGE0+i)
#define LCD_SetColumn(i) LCD_Command(LCD_COLUMNADDR0+i)

#include <reg52.h>
#define TIME 10
#define DATA P2
sbit A0=P1^3;
sbit RW=P1^4;
sbit E1=P1^5;
sbit E2=P1^6;
//=====function declare=====//
void LCM_Initial(void);
void LCD_Command(unsigned char nCommand);
void LCD_SetRam(bit bChip2,unsigned char ndata);
void LCD_Write(unsigned char npage,unsigned char ncolumn,unsigned char ndata);
void LCD_PageWrite(unsigned char npage,unsigned char idata *ndata);
unsigned char *GetTextFont(unsigned char index);
unsigned char GetIndex(unsigned char szText);
void LCD_TextOut(unsigned char x,unsigned char y,unsigned char *szText);
void Printf(unsigned char x,unsigned char y,unsigned char *szText);
//=====//

//=====ASCII Character,size 6X8=====//
unsigned char code ASCII[][6]={

{0x00,0x7e,0x21,0x21,0x21,0x7e},/*A*/

{0x00,0x7f,0x49,0x49,0x49,0x36},/*B*/

{0x00,0x3e,0x41,0x41,0x41,0x22},/*C*/

{0x00,0x7f,0x41,0x41,0x22,0x1c},/*D*/

{0x00,0x7f,0x49,0x49,0x49,0x49},/*E*/

{0x00,0x7f,0x09,0x09,0x09,0x01},/*F*/

{0x00,0x3e,0x41,0x49,0x49,0x7a},/*G*/

{0x00,0x7f,0x08,0x08,0x08,0x7f},/*H*/

{0x00,0x41,0x7f,0x41,0x00,0x00},/*I*/

{0x00,0x20,0x40,0x41,0x3f,0x01},/*J*/

```



```

{0x00,0x7f,0x08,0x14,0x22,0x41},/*K*/
{0x00,0x7f,0x40,0x40,0x40,0x40},/*L*/
{0x00,0x7f,0x02,0x0c,0x02,0x7f},/*M*/
{0x00,0x7f,0x04,0x08,0x10,0x7f},/*N*/
{0x00,0x3e,0x41,0x41,0x41,0x3e},/*O*/
{0x00,0x7f,0x09,0x09,0x09,0x06},/*P*/
{0x00,0x3e,0x41,0x41,0x41,0x3e},/*Q*/
{0x00,0x7f,0x09,0x19,0x29,0x46},/*R*/
{0x00,0x46,0x49,0x49,0x49,0x31},/*S*/
{0x00,0x01,0x01,0x7f,0x01,0x01},/*T*/
{0x00,0x3f,0x40,0x40,0x40,0x3f},/*U*/
{0x00,0x1f,0x20,0x40,0x20,0x1f},/*V*/
{0x00,0x3f,0x40,0x38,0x40,0x3f},/*W*/
{0x00,0x63,0x14,0x08,0x14,0x63},/*X*/
{0x00,0x07,0x08,0x70,0x08,0x07},/*Y*/
{0x00,0x61,0x51,0x49,0x45,0x43},/*Z*/
};

//===== LCM initial =====//
void LCM_Initial(void)
{
    LCD_Command(LCD_RESET); //Software reset
    LCD_Command(LCD_DRIVEROFF); //Static drive ON/OFF a4:Normal driving; a5:Static drive;
    LCD_Command(LCD_DUTY32); //set LCD duty cycle
    LCD_Command(0xa0); //Select ADC,A0:CW output, A1:CCW output
    LCD_Command(LCD_END); //Read-modify-write OFF
    LCD_Command(LCD_DISPLAYON); //af: display on ; ae: display off
}
//=====write command to two chips=====//
void LCD_Command(unsigned char nCommand)
{
    unsigned char i;
    A0=0;
    RW=0;
    E1=1;
    DATA=nCommand;
    i=TIME;
    while(--i);
    E1=0;
    i=TIME;
    while(--i); // chip 1

    A0=0;
    RW=0;
    E2=1;
    DATA=nCommand;
    i=TIME;
    while(--i);
    E2=0;
    i=TIME;
}

```



```

while(--i); //chip 2
}

//=====================================================write data to appointment chip=====//

void LCD_SetRam(bit bChip2,unsigned char ndata)
{
    unsigned char i;
    A0=1;
    RW=0;
    if(!bChip2)
    {
        E1=1;    //chip 1
        DATA=ndata;
        i=TIME;
        while(--i);
        E1=0;
        i=TIME;
        while(--i);
    }
    else
    {
        E2=1;    //chip 2
        DATA=ndata;
        i=TIME;
        while(--i);
        E2=0;
        i=TIME;
        while(--i);
    }
}

//=====================================================write data to appointment address=====//

void LCD_Write(unsigned char npage,unsigned char ncolumn,unsigned char ndata)
{
    LCD_SetPage(npage%4);
    LCD_SetColumn(ncolumn);
    LCD_SetRam(npage>3,ndata);
}

//=====================================================write data to appointment page=====//
void LCD_PageWrite(unsigned char npage,unsigned char idata *ndata)
{
    unsigned char i;
    bit bChip2=npage>3;
    LCD_SetPage(npage%4);
    LCD_SetColumn(0);
    for(i=0;i<61;i++)
        LCD_SetRam(bChip2,ndata[i]);
}

unsigned char *GetTextFont(unsigned char index)
{
    static unsigned char Font[6];
    unsigned char i;
    for(i=0;i<6;i++)
        Font[i]=ASCII[index][i];
    return Font;
}

//=====================================================display character on screen=====//
void LCD_TextOut(unsigned char x,unsigned char y,unsigned char *szText)
{
    unsigned char i;
    bit bChip2;

```



```

x%=20;
y%=4;
if(x>=10)
{
x-=10;
y+=4;
}
bChip2=y>3;
LCD_SetPage(y%4);
LCD_SetColumn(x*6);
for(i=0;i<6;i++) LCD_SetRam(bChip2,szText[i]);
}

unsigned char GetIndex(unsigned char szText)
{
unsigned char code TAB[]={
'A','B','C','D','E','F','G','H','I','J','K','L','M','N','O','P','Q',
'R','S','T','U','V','W','X','Y','Z','a','b','c','d','e','f','g','h','i','j',
'k','l','m','n','o','p','q','r','s','t','u','v','w','x','y','z',' ','1','2','3',
'4','5','6','7','8','9','0','-','=','\','~','!','@','#','$','%','^','&','*','
(',')','_','+','|','[','\'],';',':','"','/','{',' ',' ',' ','<','>','?';
};
unsigned char i;
for(i=0;i<sizeof(TAB);i++)
if(szText==TAB[i]) return i;
return 0x00;
}

//=====display character=====//
void Printf(unsigned char x,unsigned char y,unsigned char *szText)
{
unsigned char *Text;
while(*szText)
{
Text=GetTextFont(GetIndex(*szText));
LCD_TextOut(x++,y,Text);
if(x==20) break;
szText++;
}
}

void main()
{
LCM_Initial();
while(1)
{
//transfer subprogram to test
// Printf(0,0,0);
}
}

```

11. Precautions For Using LCD Modules

Handing Precautions

- (1) The display panel is made of glass. Do not subject it to a mechanical shock by dropping it or impact.
- (2) If the display panel is damaged and the liquid crystal substance leaks out, be sure not to get any in your mouth. If the substance contacts your skin or clothes, wash it off using soap and water.



(3) Do not apply excessive force to the display surface or the adjoining areas since this may cause the color tone to vary.

(4) The polarizer covering the display surface of the LCD module is soft and easily scratched. Handle this polarizer carefully.

(5) If the display surface becomes contaminated, breathe on the surface and gently wipe it with a soft dry cloth. If it is heavily contaminated, moisten cloth with one of the following solvents :

- Isopropyl alcohol
- Ethyl alcohol

(6) Solvents other than those above-mentioned may damage the polarizer. Especially, do not use the following.

- Water
- Ketone
- Aromatic solvents

(7) Exercise care to minimize corrosion of the electrode. Corrosion of the electrodes is accelerated by water droplets, moisture condensation or a current flow in a high-humidity environment.

(8) Install the LCD Module by using the mounting holes. When mounting the LCD module make sure it is free of twisting, warping and distortion. In particular, do not forcibly pull or bend the I/O cable or the backlight cable.

(9) Do not attempt to disassemble or process the LCD module.

(10) NC terminal should be open. Do not connect anything.

(11) If the logic circuit power is off, do not apply the input signals.

(12) To prevent destruction of the elements by static electricity, be careful to maintain an optimum work environment.

- Be sure to ground the body when handling the LCD modules.
- Tools required for assembling, such as soldering irons, must be properly grounded.
- To reduce the amount of static electricity generated, do not conduct assembling and other work under dry conditions.

- The LCD module is coated with a film to protect the display surface. Exercise care when peeling off this protective film since static electricity may be generated.

Storage Precautions

When storing the LCD modules, avoid exposure to direct sunlight or to the light of fluorescent lamps. Keep the modules in bags (avoid high temperature / high humidity and low temperatures below 0°C). Whenever possible, the LCD modules should be stored in the same conditions in which they were shipped from our company.

Others

Liquid crystals solidify under low temperature (below the storage temperature range) leading to defective orientation or the generation of air bubbles (black or white). Air bubbles may also be generated if the module is subject to a low temperature.

If the LCD modules have been operating for a long time showing the same display patterns, the display patterns may remain on the screen as ghost images and a slight contrast irregularity may also appear. A normal operating status can be regained by suspending use for some time. It should be noted that this phenomenon does not adversely affect performance reliability.

To minimize the performance degradation of the LCD modules resulting from destruction caused by static electricity etc., exercise care to avoid holding the following sections when handling the modules.

- Exposed area of the printed circuit board.
- Terminal electrode sections.

Liquid Crystal Display Modules

LCD is composed of glass and polarizer. Pay attention to the following items when handling.

(1) Please keep the temperature within specified range for use and storage. Polarization degradation, bubble generation or polarizer peel-off may occur with high temperature and high humidity.

(2) Do not touch, push or rub the exposed polarizers with anything harder than an HB pencil lead (glass, tweezers, etc.).

(3) N-hexane is recommended for cleaning the adhesives used to attach front/rear polarizers and reflectors made of organic substances which will be damaged by chemicals such as acetone, toluene, ethanol and isopropylalcohol.

(4) When the display surface becomes dusty, wipe gently with absorbent cotton or other soft material like chamois soaked in petroleum benzine. Do not scrub hard to avoid damaging the display surface.

(5) Wipe off saliva or water drops immediately, contact with water over a long period of time may cause deformation or color fading.

(6) Avoid contacting oil and fats.

(7) Condensation on the surface and contact with terminals due to cold will damage, stain or dirty the polarizers. After products are tested at low temperature they must be warmed up in a container before coming in contact with room temperature air.

(8) Do not put or attach anything on the display area to avoid leaving marks on.

(9) Do not touch the display with bare hands. This will stain the display area and degrade insulation between terminals (some cosmetics are determined to the polarizers).

(10) As glass is fragile. It tends to become or chipped during handling especially on the edges. Please avoid dropping or jarring.

Installing LCD Modules

The hole in the printed circuit board is used to fix LCM as shown in the picture below. Attend to the following items when installing the LCM.

(1) Cover the surface with a transparent protective plate to protect the polarizer and LC cell.

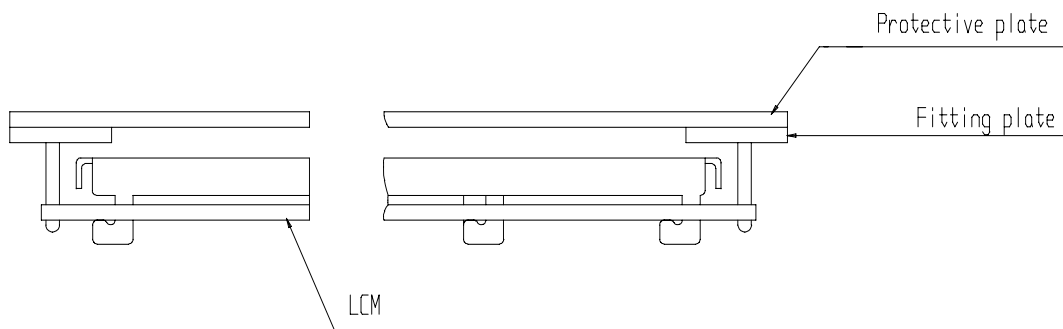

(2) When assembling the LCM into other equipment, the spacer to the bit between the LCM and the fitting plate should have enough height to avoid causing stress to the module surface, refer to the individual specifications for measurements. The measurement tolerance should be ± 0.1 mm.

Precaution for Handling LCD Modules

Since LCM has been assembled and adjusted with a high degree of precision, avoid applying excessive shocks to the module or making any alterations or modifications to it.

(1) Do not alter, modify or change the shape of the tab on the metal frame.

(2) Do not make extra holes on the printed circuit board, modify its shape or change the positions of components to be attached.

(3) Do not damage or modify the pattern writing on the printed circuit board.

(4) Absolutely do not modify the zebra rubber strip (conductive rubber) or heat seal connector.

(5) Except for soldering the interface, do not make any alterations or modifications with a soldering iron.

(6) Do not drop, bend or twist LCM.

(7) In order to avoid the cracking of the FPC, you should pay attention to the area of FPC (R50mm) where the FPC was bent. the edge of coverlay; the area of surface of Ni-Au plating, the area of soldering land, the area of through hole.

Electro-Static Discharge Control

Since this module uses a CMOS LSI, the same careful attention should be paid to electrostatic discharge as for an ordinary CMOS IC.

(1) Make certain that you are grounded when handling LCM.

(2) Before remove LCM from its packing case or incorporating it into a set, be sure the module and your body have the same electric potential.



(3) When soldering the terminal of LCM, make certain the AC power source for the soldering iron does not leak.

(4) When using an electric screwdriver to attach LCM, the screwdriver should be of ground potential to minimize as much as possible any transmission of electromagnetic waves produced sparks coming from the commutator of the motor.

(5) As far as possible make the electric potential of your work clothes and that of the work bench the ground potential.

(6) To reduce the generation of static electricity be careful that the air in the work is not too dried. A relative humidity of 50%-60% is recommended.

Precaution for soldering to the LCM

(1) Observe the following when soldering lead wire, connector cable and etc. to the LCM.

- Soldering iron temperature : $260^{\circ}\text{C} \pm 10^{\circ}\text{C}$.
- Soldering time : 3-4 sec.
- Solder : eutectic solder.

If soldering flux is used, be sure to remove any remaining flux after finishing to soldering operation. (This does not apply in the case of a non-halogen type of flux.) It is recommended that you protect the LCD surface with a cover during soldering to prevent any damage due to flux spatters.

(2) When soldering the electroluminescent panel and PC board, the panel and board should not be detached more than three times. This maximum number is determined by the temperature and time conditions mentioned above, though there may be some variance depending on the temperature of the soldering iron.

(3) When remove the electroluminescent panel from the PC board, be sure the solder has completely melted, the soldered pad on the PC board could be damaged.

(4) Soldering iron is not allowed to touch the surface of FPC's cover film directly.

Precautions for Operation

(1) Viewing angle varies with the change of liquid crystal driving voltage (VO). Adjust VO to show the best contrast.

(2) Driving the LCD in the voltage above the limit shortens its life.

(3) Response time is greatly delayed at temperature below the operating temperature range. However, this does not mean the LCD will be out of the order. It will recover when it returns to the specified temperature range.

(4) If the display area is pushed hard during operation, the display will become abnormal. However, it will return to normal if it is turned off and then back on.

(5) Condensation on terminals can cause an electrochemical reaction disrupting the terminal circuit. Therefore, it must be used under the relative condition of 40°C , 50% RH.

(6) When turning the power on, input each signal after the positive/negative voltage becomes stable.

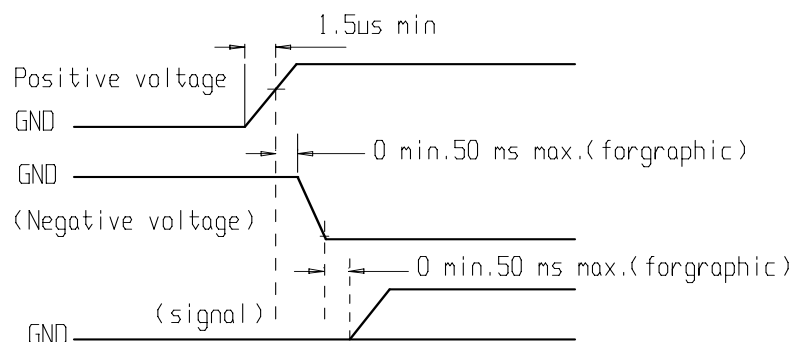

Storage

When storing LCDs as spares for some years, the following precaution are necessary.

(1) Store them in a sealed polyethylene bag. If properly sealed, there is no need for dessicant.

(2) Store them in a dark place. Do not expose to sunlight or fluorescent light, keep the temperature between 0°C and 35°C .



(3) The polarizer surface should not come in contact with any other objects. (We advise you to store them in the container in which they were shipped.)

(4) Environmental conditions :

- Do not leave them for more than 160hrs. at 70°C.
- Should not be left for more than 48hrs. at -20°C.

Safety

(1) It is recommended to crush damaged or unnecessary LCDs into pieces and wash them off with solvents such as acetone and ethanol, which should later be burned.

(2) If any liquid leaks out of a damaged glass cell and comes in contact with the hands, wash off thoroughly with soap and water.

Limited Warranty

Unless agreed between EAST and customer, EAST will replace or repair any of its LCD modules which are found to be functionally defective when inspected in accordance with EAST LCD acceptance standards (copies available upon request) for a period of one year from date of shipments. Cosmetic/visual defects must be returned to EAST within 90 days of shipment. Confirmation of such date shall be based on freight documents. The warranty liability of EAST limited to repair and/or replacement on the terms set forth above. EAST will not be responsible for any subsequent or consequential events.

Return LCM under warranty

No warranty can be granted if the precautions stated above have been disregarded. The typical examples of violations are :

- Broken LCD glass.
- PCB eyelet's damaged or modified.
- PCB conductors damaged.
- Circuit modified in any way, including addition of components.
- PCB tampered with by grinding, engraving or painting varnish.
- soldering to or modifying the bezel in any manner.

Module repairs will be invoiced to the customer upon mutual agreement. Modules must be returned with sufficient description of the failures or defects. Any connectors or cable installed by the customer must be removed completely without damaging the PCB's eyelet, conductors and terminals.